

Test Paper : II	Test Booklet Serial No. : _____								
Test Subject : PHYSICAL SCIENCE	OMR Sheet No. : _____								
Test Subject Code : K-2514	Roll No. <table border="1" style="display: inline-table; vertical-align: middle;"> <tr> <td style="width: 20px; height: 20px;"></td> <td style="width: 20px; height: 20px;"></td> <td style="width: 20px; height: 20px;"></td> <td style="width: 20px; height: 20px;"></td> <td style="width: 20px; height: 20px;"></td> <td style="width: 20px; height: 20px;"></td> <td style="width: 20px; height: 20px;"></td> <td style="width: 20px; height: 20px;"></td> </tr> </table> (Figures as per admission card)								

Name & Signature of Invigilator/s	
Signature: _____	Signature: _____
Name : _____	Name : _____
Paper : II	
Subject : PHYSICAL SCIENCE	
Time : 1 Hour 15 Minutes	Maximum Marks : 100

Number of Pages in this Booklet : 8 Number of Questions in this Booklet : 50

<p style="text-align: center;">ಅಭ್ಯರ್ಥಿಗಳಿಗೆ ಸೂಚನೆಗಳು</p> <ol style="list-style-type: none"> ಈ ಪುಟದ ಮೇಲ್ಭಾಗದಲ್ಲಿ ಒದಗಿಸಿದ ಸ್ಥಳದಲ್ಲಿ ನಿಮ್ಮ ರೋಲ್ ನಂಬರನ್ನು ಬರೆಯಿರಿ. ಈ ಪತ್ರಿಕೆಯು ಬಹು ಆಯ್ಕೆ ವಿಧದ ಐವತ್ತು ಪ್ರಶ್ನೆಗಳನ್ನು ಒಳಗೊಂಡಿದೆ. ಪರೀಕ್ಷೆಯ ಪ್ರಾರಂಭದಲ್ಲಿ ಪ್ರಶ್ನೆಪುಸ್ತಕವನ್ನು ನಿಮಗನಿಡಲಾಗುವುದು. ಮೊದಲ 5 ನಿಮಿಷಗಳಲ್ಲಿ ನೀವು ಪುಸ್ತಕವನ್ನು ತೆರೆಯಲು ಮತ್ತು ಕೆಳಗಿನಂತೆ ಕಡ್ಡಾಯವಾಗಿ ಪರೀಕ್ಷಿಸಲು ಕೋರಲಾಗಿದೆ. <ol style="list-style-type: none"> ಪ್ರಶ್ನೆಪುಸ್ತಕಕ್ಕೆ ಪ್ರವೇಶಾವಕಾಶ ಪಡೆಯಲು, ಈ ಹೊಂದಿಕೆ ಪುಟದ ಅಂಚಿನ ಮೇಲಿರುವ ಪೇಪರ್ ಸೀಲನ್ನು ಹರಿಯಿರಿ. ಸ್ಕ್ರೇಪ್ ಸೀಲ್ ಇಲ್ಲದ ಪ್ರಶ್ನೆಪುಸ್ತಕ ಸ್ವೀಕರಿಸಬೇಡಿ. ತೆರೆದ ಪುಸ್ತಕವನ್ನು ಸ್ವೀಕರಿಸಬೇಡಿ. ಪುಸ್ತಕಿಯಲ್ಲಿನ ಪ್ರಶ್ನೆಗಳ ಸಂಖ್ಯೆ ಮತ್ತು ಪುಟಗಳ ಸಂಖ್ಯೆಯನ್ನು ಮುಖಪುಟದ ಮೇಲೆ ಮುದ್ರಿಸಿದ ಮಾಹಿತಿಯೊಂದಿಗೆ ತಾಳಿ ನೋಡಿ. ಪುಟಗಳು/ಪ್ರಶ್ನೆಗಳು ಕಾಣೆಯಾದ, ಅಥವಾ ದ್ವಿಪ್ರತಿ ಅಥವಾ ಅನುಕ್ರಮವಾಗಿಲ್ಲದ ಅಥವಾ ಇತರ ಯಾವುದೇ ವ್ಯತ್ಯಾಸದ ದೋಷಪೂರಿತ ಪುಸ್ತಕವನ್ನು ಕೂಡಲೆ 5 ನಿಮಿಷದ ಅವಧಿ ಒಳಗೆ, ಸಂವೀಕ್ಷಕರಿಂದ ಸರಿ ಇರುವ ಪುಸ್ತಕಕ್ಕೆ ಬದಲಾಯಿಸಿಕೊಳ್ಳಬೇಕು. ಆ ಬಳಿಕ ಪ್ರಶ್ನೆ ಪತ್ರಿಕೆಯನ್ನು ಬದಲಾಯಿಸಲಾಗುವುದಿಲ್ಲ, ಯಾವುದೇ ಹೆಚ್ಚು ಸಮಯವನ್ನೂ ಕೊಡಲಾಗುವುದಿಲ್ಲ. ಪ್ರತಿಯೊಂದು ಪ್ರಶ್ನೆಗೂ (A), (B), (C) ಮತ್ತು (D) ಎಂದು ಗುರುತಿಸಿದ ನಾಲ್ಕು ಪರ್ಯಾಯ ಉತ್ತರಗಳಿವೆ. ನೀವು ಪ್ರಶ್ನೆಯ ಎದುರು ಸರಿಯಾದ ಉತ್ತರದ ಮೇಲೆ, ಕೆಳಗೆ ಕಾಣಿಸಿದಂತೆ ಅಂಡಾಕೃತಿಯನ್ನು ಕವಾಚಿಸಬೇಕು. ಉದಾಹರಣೆ: <table style="display: inline-table; vertical-align: middle;"> <tr> <td style="border: 1px solid black; border-radius: 50%; width: 15px; height: 15px; text-align: center;">A</td> <td style="border: 1px solid black; border-radius: 50%; width: 15px; height: 15px; text-align: center;">B</td> <td style="border: 1px solid black; border-radius: 50%; width: 15px; height: 15px; background-color: black; text-align: center;">C</td> <td style="border: 1px solid black; border-radius: 50%; width: 15px; height: 15px; text-align: center;">D</td> </tr> </table> (C) ಸರಿಯಾದ ಉತ್ತರವಾಗಿದ್ದಾಗ. ಪ್ರಶ್ನೆ ಪತ್ರಿಕೆ I ರಲ್ಲಿ ಕೊಟ್ಟಿರುವ OMR ಉತ್ತರ ಹಾಳೆಯಲ್ಲಿ, ಪ್ರಶ್ನೆ ಪತ್ರಿಕೆ I ಮತ್ತು ಪ್ರಶ್ನೆ ಪತ್ರಿಕೆ II ರಲ್ಲಿ ಇರುವ ಪ್ರಶ್ನೆಗಳಿಗೆ ನಿಮ್ಮ ಉತ್ತರಗಳನ್ನು ಸೂಚಿಸತಕ್ಕದ್ದು. OMR ಉತ್ತರ ಹಾಳೆಯಲ್ಲಿ ಅಂಡಾಕೃತಿಯಲ್ಲದ ಬೇರೆ ಯಾವುದೇ ಸ್ಥಳದಲ್ಲಿ ಉತ್ತರವನ್ನು ಗುರುತಿಸಿದರೆ, ಅದರ ಮಾಲ್ಯಮಾಪನ ಮಾಡಲಾಗುವುದಿಲ್ಲ. OMR ಉತ್ತರ ಹಾಳೆಯಲ್ಲಿ ಕೊಟ್ಟ ಸೂಚನೆಗಳನ್ನು ಜಾಗರೂಕತೆಯಿಂದ ಓದಿರಿ. ಎಲ್ಲಾ ಕೆಲಸವನ್ನು ಪುಸ್ತಕಿಯ ಕೊನೆಯಲ್ಲಿ ಮಾಡತಕ್ಕದ್ದು. ನಿಮ್ಮ ಗುರುತನ್ನು ಬಹಿರಂಗಪಡಿಸಬಹುದಾದ ನಿಮ್ಮ ಹೆಸರು ಅಥವಾ ಯಾವುದೇ ಚಿಹ್ನೆಯನ್ನು ಸಂಗತವಾದ ಸ್ಥಳ ಹೊರತು ಪಡಿಸಿ, OMR ಉತ್ತರ ಹಾಳೆಯ ಯಾವುದೇ ಭಾಗದಲ್ಲಿ ಬರೆದರೆ, ನೀವು ಅನರ್ಹತೆಗೆ ಬಾಧ್ಯರಾಗಿರುತ್ತೀರಿ. ಪರೀಕ್ಷೆಯು ಮುಗಿದನಂತರ, ಕಡ್ಡಾಯವಾಗಿ OMR ಉತ್ತರ ಹಾಳೆಯನ್ನು ಸಂವೀಕ್ಷಕರಿಗೆ ನೀವು ಹಿಂತಿರುಗಿಸಬೇಕು ಮತ್ತು ಪರೀಕ್ಷಾ ಕೊಠಡಿಯ ಹೊರಗೆ OMR ನ್ನು ನಿಮ್ಮೊಂದಿಗೆ ಕೊಂಡೊಯ್ಯ ಕೂಡದು. ಪರೀಕ್ಷೆಯ ನಂತರ, ಪರೀಕ್ಷಾ ಪ್ರಶ್ನೆ ಪತ್ರಿಕೆಯನ್ನು ಮತ್ತು ನಕಲು OMR ಉತ್ತರ ಹಾಳೆಯನ್ನು ನಿಮ್ಮೊಂದಿಗೆ ತೆಗೆದುಕೊಂಡು ಹೋಗಬಹುದು. ನೀಲಿ/ಕಪ್ಪು ಬಾಲ್ ಪಾಯಿಂಟ್ ಪೆನ್ ಮಾತ್ರವೇ ಉಪಯೋಗಿಸಿರಿ. ಕ್ಯಾಲ್ಕುಲೇಟರ್ ಅಥವಾ ಲಾಗ್ ಟೇಬಲ್ ಇತ್ಯಾದಿಯ ಉಪಯೋಗವನ್ನು ನಿಷೇಧಿಸಲಾಗಿದೆ. ಸರಿ ಅಲ್ಲದ ಉತ್ತರಗಳಿಗೆ ಋಣ ಅಂಕ ಇರುವುದಿಲ್ಲ. 	A	B	C	D	<p style="text-align: center;">Instructions for the Candidates</p> <ol style="list-style-type: none"> Write your roll number in the space provided on the top of this page. This paper consists of fifty multiple-choice type of questions. At the commencement of examination, the question booklet will be given to you. In the first 5 minutes, you are requested to open the booklet and compulsorily examine it as below : <ol style="list-style-type: none"> To have access to the Question Booklet, tear off the paper seal on the edge of this cover page. Do not accept a booklet without sticker-seal and do not accept an open booklet. Tally the number of pages and number of questions in the booklet with the information printed on the cover page. Faulty booklets due to pages/questions missing or duplicate or not in serial order or any other discrepancy should be got replaced immediately by a correct booklet from the invigilator within the period of 5 minutes. Afterwards, neither the Question Booklet will be replaced nor any extra time will be given. Each item has four alternative responses marked (A), (B), (C) and (D). You have to darken the oval as indicated below on the correct response against each item. Example : <table style="display: inline-table; vertical-align: middle;"> <tr> <td style="border: 1px solid black; border-radius: 50%; width: 15px; height: 15px; text-align: center;">A</td> <td style="border: 1px solid black; border-radius: 50%; width: 15px; height: 15px; text-align: center;">B</td> <td style="border: 1px solid black; border-radius: 50%; width: 15px; height: 15px; background-color: black; text-align: center;">C</td> <td style="border: 1px solid black; border-radius: 50%; width: 15px; height: 15px; text-align: center;">D</td> </tr> </table> where (C) is the correct response. Your responses to the questions are to be indicated in the OMR Sheet kept inside the Paper I Booklet only. If you mark at any place other than in the ovals in the Answer Sheet, it will not be evaluated. Read the instructions given in OMR carefully. Rough Work is to be done in the end of this booklet. If you write your name or put any mark on any part of the OMR Answer Sheet, except for the space allotted for the relevant entries, which may disclose your identity, you will render yourself liable to disqualification. You have to return the test OMR Answer Sheet to the invigilators at the end of the examination compulsorily and must NOT carry it with you outside the Examination Hall. You can take away question booklet and carbon copy of OMR Answer Sheet soon after the examination. Use only Blue/Black Ball point pen. Use of any calculator or log table etc., is prohibited. There is no negative marks for incorrect answers. 	A	B	C	D
A	B	C	D						
A	B	C	D						



PHYSICAL SCIENCE
Paper – II

Note : This paper contains **fifty (50)** objective type questions. **Each** question carries **two (2)** marks. **All** questions are **compulsory**.

1. Eigen values of the matrix

$$\begin{pmatrix} \cos \theta & -\sin \theta \\ \sin \theta & \cos \theta \end{pmatrix} \text{ will be}$$

- (A) $\lambda = e^{+i\theta}$ and $e^{-i\theta}$
(B) $\lambda = \sin \theta$ and $\cos \theta$
(C) $\lambda = -\sin \theta$ and $-\cos \theta$
(D) $\lambda = e^{\theta}$ and $e^{-\theta}$

2. The value of $L\{\sinh kt\}$ is

- (A) $\frac{s}{s^2 - k^2}$
(B) $\frac{k}{s^2 - k^2}$
(C) $\frac{s}{s^2 + k^2}$
(D) $\frac{k}{s^2 + k^2}$

3. Which of the following recurrence relations is not true ?

- (A) $xP'_1(x) = 1P_1(x) + P_{1-1}'(x)$
(B) $H'_n(x) = 2n H_{n-1}(x)$
(C) $2J'_n(x) = J_{n-1}(x) + J_{n+1}(x)$
(D) $L'_n(x) = nL_n(x) - nL_{n-1}(x)$

4. Which of the following is NOT correct with regard to the normal distribution ?

- 1) It is a continuous distribution
2) It is a bell shaped curve symmetric about the mean
3) Its curvature depends on the value of standard deviation, σ
4) Its curvature depends on the value of the mean
5) The mean and the mode coincide
6) The mean and the median do not coincide
7) The points of inflection of the curve occur at $x = \pm \sigma$

- (A) 4 and 6
(B) 1, 2 and 6
(C) 2, 3, 4 and 7
(D) 1, 3, 4, 5 and 7

5. If $f(x) = x$ for $0 \leq x \leq 2$, and $f(x)$ is expanded in Fourier series, then the constant term in the series is

- (A) 0 (B) 1
(C) 2 (D) 3

6. The Taylor's series expansion of $\sin x$ is

- (A) $1 - \frac{x^2}{2!} + \frac{x^4}{4!}$ (B) $1 + \frac{x^2}{4!} + \frac{x^4}{4!}$
(C) $x + \frac{x^2}{3!} + \frac{x^4}{5!}$ (D) $x - \frac{x^2}{3!} + \frac{x^4}{5!}$



7. The value of the contour integral $\int \frac{dx}{z^2(z+3)}$, where c denotes the unit circle $|z| = 1$ traced in the contour clockwise direction is
(A) 0 (B) $2\pi i$
(C) $2\pi i/3$ (D) $-2\pi i/9$
8. Identify the correct statement for the following vectors : $a = 6\hat{i} - 9\hat{j}$, and $b = -2\hat{i} + 3\hat{j}$.
(A) The vectors a and b are linearly independent
(B) The vectors a and b are linearly dependent
(C) The vectors a and b are orthogonal
(D) The vectors a and b are normalized
9. Constraints that can be expressed in terms of an equation relating to co-ordinates of system and time.
(A) Holonomic
(B) Non-Holonomic
(C) Scleronomous
(D) Rheonomous
10. The Lagrangian is a function of
(A) q_k, p_k (B) q_k, \dot{q}_k
(C) q_k, \dot{p}_k (D) p_k, \dot{p}_k
11. For repulsive inverse square forces, the shape of the orbit is
(A) Hyperbolic
(B) Elliptical
(C) Circular
(D) Parabolic
12. Kepler's second law states that
(A) Areal velocity is zero
(B) Areal velocity is constant
(C) Angular momentum is not constant
(D) Linear velocity is constant
13. In the Hamiltonian formalism
(A) $H = \sum_k p_k \dot{q}_k - L$
(B) $H = \sum_k p_k q_k - L$
(C) $L = \sum_k p_k \dot{q}_k + H$
(D) $L = \sum_k p_k q_k + H$
14. Hamilton's principal function S and Hamilton's characteristic function W for conservative system are related as
(A) $S = W$ (B) $S = Et$
(C) $S = W + Et$ (D) $S = W - Et$
15. The Lagrangian for a particle of charge 'e' in an electromagnetic field is given by
(A) $T - e\phi + \frac{e}{c} A \cdot V$
(B) $T + e\phi + \frac{e}{c} A \cdot V$
(C) $T + e\phi - \frac{e}{c} A \cdot V$
(D) $T - e\phi - \frac{e}{c} A \cdot V$
16. The length of space vehicle is 100 m on the ground. When it is in flight, its length as observed on the ground is 99 m the speed of the vehicle in the space is
(A) $42.32 \times 10^8 \text{ ms}^{-1}$
(B) $42.32 \times 10^6 \text{ ms}^{-1}$
(C) $42.32 \times 10^{10} \text{ ms}^{-1}$
(D) $42.32 \times 10^{12} \text{ ms}^{-1}$



17. A rigid body moving freely in space has _____ degrees of freedom.
(A) 3 (B) 6
(C) 9 (D) 4
18. Which of the following potential satisfies Laplace equation ?
(A) $V = 2x^2 - 3y^2 + z^2$
(B) $V = x^3 - xy$
(C) $V = 2y^2$
(D) $V = 4z^2 - 3$
19. If the potential field is given by $V(x, y, z) = 2x^2y - 5z$, the magnitude of the electric field intensity at the point P (1, 2, 3) is
(A) -11V (B) -11 V/m
(C) 9.6 V (D) 9.6 V/m
20. In a perfect dielectric material a polarization $P = 15\hat{k}$ pC/m² is produced when the electric field intensity is $E = 3\hat{k}$ V/m. The electric susceptibility is
(A) 1.77 (B) 1.565
(C) 0.6389 (D) 0.565
21. Magnetic field due to a vector potential $A = (0, Bx^2, 0)$ at a point (1, 0, 0) is
(A) B (B) 2B
(C) B² (D) -2B
22. Biot-Savart law in vector notation is
(A) $B = \frac{\mu_0}{4\pi} \int \frac{dl \times r}{r^2}$
(B) $B = \frac{\mu_0}{4\pi} \int \frac{dl \times r}{r}$
(C) $B = \frac{\mu_0}{4\pi} \int \frac{dl \cdot r}{r^3}$
(D) $B = \frac{\mu_0}{4\pi} \int \frac{dl \times r}{r^3}$
23. Poisson's equation states that
(A) $\nabla^2 V = -\frac{\rho}{\epsilon}$ (B) $\nabla^2 V = \frac{\rho}{\epsilon}$
(C) $\nabla V = -\frac{\rho}{\epsilon}$ (D) $\nabla V = \frac{\rho^2}{\epsilon}$
24. For a good conductor skin depth varies
(A) Directly as conductivity
(B) Inversely as conductivity
(C) Inversely as the square root of conductivity
(D) Directly as the square root of conductivity
25. Lorentz gauge is represented by
(A) $\nabla \cdot A = 0$
(B) $\nabla \cdot A \neq 0$
(C) $\frac{\partial \phi}{\partial t} = 0$
(D) $\frac{\partial \phi}{\partial t} \neq 0$
26. Stern-Gerlach experiment demonstrated the existence of
(A) Electron magnetic moment
(B) Electron spin
(C) Electron charge
(D) Neutron charge
27. The operator $-\hbar^2 \frac{\partial^2}{\partial x^2}$ is for
(A) Momentum
(B) \hbar^2
(C) Kinetic energy
(D) Force



28. Which of the following commutation relations is NOT correct ?
- (A) $[L^2, L_z] = 0$
(B) $[L_x, L_y] = i\hbar L_z$
(C) $[L_z, L_+] = \hbar L_+$
(D) $[L_z, L_-] = \hbar L_-$
29. The eigenfunctions of the linear harmonic oscillator are called
- (A) Legendre polynomials
(B) Bessel functions
(C) Hermite polynomials
(D) Laguerre polynomials
30. If T is the kinetic energy of an electron of mass ' m ', the deBroglie wavelength of the electron is
- (A) $\frac{h}{2mT}$ (B) $\frac{\hbar}{2mT}$
(C) $\frac{h}{\sqrt{2mT}}$ (D) $\frac{\hbar}{\sqrt{2mT}}$
31. The first order correction to the energy of the n^{th} state due to a time independent perturbation V is given by
- (A) $\langle n|V|n\rangle$ (B) $|\langle n|V|n\rangle|^2$
(C) 0 (D) $\langle n|V|n\rangle^2$
32. Pauli's exclusion principle is valid only for
- (A) Bosons (B) Fermions
(C) Phonons (D) Excitons
33. The expectation value $\langle r \rangle$ of the position of the electron in the ground state of an hydrogen atom is _____ times radius of the first Bohr orbit.
- (A) 0.5
(B) 1.0
(C) 1.5
(D) 2.0
34. The tunnelling through a potential barrier increases if
- (A) Height and width of the barrier are increased
(B) Height and width of the barrier are reduced
(C) Height is increased and width reduced
(D) Height is reduced and width increased
35. The energy corresponding to the ground ($n = 1$) state of a particle confined in a one-dimensional square well of side 10 nm is 10 meV. The energies of the next two higher ($n = 2$ and $n = 3$) states are
- (A) 20 meV, 30 meV
(B) 40 meV, 90 meV
(C) 40 eV, 90 eV
(D) 20 eV, 30 eV



36. A system in an external field will be in equilibrium if the following physical parameters of each component of the system is constant throughout, that is
- (A) Volume and chemical potential
 - (B) Temperature and chemical potential
 - (C) Temperature and pressure
 - (D) Volume, temperature and pressure
37. In quantum statistics the volume of phase cells is (h being Planck constant)
- (A) h^2
 - (B) h^{-2}
 - (C) h^3
 - (D) h^{-3}
38. The collection of large number of essentially independent systems having the same energy E , volume V and number of particles N are called
- (A) Ensemble
 - (B) Grand canonical ensemble
 - (C) Canonical ensemble
 - (D) Micro canonical ensemble
39. The partition function 'Q' of a system that contains large number (N) of molecules freely moving inside a volume V is related to single particle partition function 'q' as
- (A) $Q = qN$
 - (B) $Q = q/N$
 - (C) $Q = q^N$
 - (D) $Q = q^{-N}$
40. Which of the following statements is NOT true ?
- (A) Bose-Einstein statistics deals with distinguishable particles
 - (B) Fermions obey Pauli's exclusion principle
 - (C) Maxwell-Boltzmann statistics deals with distinguishable particles
 - (D) Fermi-Dirac statistics deals with indistinguishable particles.
41. Boltzmann relation between entropy, S , and probability, W , is
- (A) $S = \ln(W)$
 - (B) $S = (\ln W)/k_B$
 - (C) $S = k_B/\ln(W)$
 - (D) $S = k_B \ln(W)$
42. With regard to the Fermi-Dirac distribution function $f(E)$ where E refers to energy, which of the following is TRUE at room temperature ?
- (A) $f(E_F)$ has a value of $1/2$ (E_F being the Fermi energy)
 - (B) $f(E)$ is a step function
 - (C) States with $E < E_F$ are filled completely
 - (D) $f(E)$ is large and tends to ∞ as E decreases much below E_F
43. For $T < T_b$ (T_b being the Bose temperature), the system is in a
- (A) Gas phase
 - (B) Condensed phase
 - (C) Mixture of gas phase and condensed phase
 - (D) Neither gas phase nor condensed phase



44. The width of the depletion layer of a junction
(A) Is independent of applied voltage
(B) Decreases with light doping
(C) Increases under reverse bias
(D) Increases with heavy doping
45. The band gap of a semiconducting material used to make an LED is 1.43 eV. What will be the minimum wavelength of the radiation emitted by this LED, in μm ?
(A) 8.68 (B) 8.68×10^{-1}
(C) 8.68×10^{-2} (D) 8.68×10^{-6}
46. **Assertion (A)** : An array of flip-flops facilitates to develop memory devices.
Reason (R) : An array of flip-flops can store binary information temporarily.
(A) (A) is correct, but (R) is incorrect
(B) (A) is incorrect, but (R) is correct
(C) Both (A) and (R) are incorrect
(D) Both (A) and (R) are correct
47. The circuit shown here can be used as

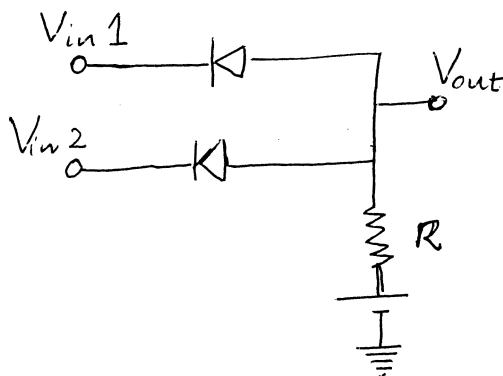

- (A) OR gate (B) NOR gate
(C) AND gate (D) NAND gate

48. The band width of frequency response curve of amplifier increases in
(A) Positive feedback configuration
(B) Negative feedback configuration
(C) CE configuration
(D) CB configuration
49. In a sequence of computations, the process is NOT a stable process, if
(A) The rate of accumulation of error decreases
(B) The rate of accumulation of error decreases, but rate of relative accumulation error decreases
(C) The rate of accumulation of error decreases, and rate of relative accumulation error increases
(D) The process is not related to the rate of accumulation of relative error
50. Identify the correct order in which the following four devices were invented ?
(A) BJT, diode, microprocessor, FET
(B) BJT, diode, FET, microprocessor
(C) Diode, BJT, microprocessor, FET
(D) BJT, microprocessor, diode, FET



Total Number of Pages : 8

Space for Rough Work